



ELEVATOR PRODUCTS INC.

2019

PRODUCT CATALOG

A WORLDWIDE SUPPLIER OF QUALITY COMPONENTS FOR THE ELEVATOR INDUSTRY

(800) 783-4633
www.SCSElevatorProducts.com



**NOW
OPEN**

SHOP SCS ELEVATOR PRODUCTS ONLINE
WWW.SCSELEVATORPRODUCTS.COM

CUSTOMER SUPPORT

(800) 783-4633

WWW.SCSELEVATORPRODUCTS.COM

info@scelevatorproducts.com

OUR DOOR IS ALWAYS OPEN

Here at SCS we are wholeheartedly committed to delivering the highest quality products while offering world-class customer service. Our team takes pride in every facet of what we do. We invite you to get to know who we are. Our doors are always open.





ELEVATOR PRODUCTS INC.
(800) 783-4633

WELCOME

For over four decades, SCS Elevator Products has incorporated innovations to set the standard of excellence in elevator components.

Throughout our 40 year history, SCS has built a reputation for designing and manufacturing the highest quality products for customers while maintaining an industry leading standard of customer service.

OUR MISSION is to continually build and maintain a team of honest, hard-working successful individuals who are committed to servicing our customers. We promise to produce the highest quality products through a certified Quality Management System. We are dedicated to continuous process improvements and to maintain our ISO 9001 certification. Our ethics stand on high integrity and solid core values in our day-to-day commitment to our customers and to our company.

**WE PROVIDE A SAFE WORK
ENVIRONMENT FOR OUR EMPLOYEES.**



Proudly made in the USA, Shipped Worldwide

WHAT CAN **SCS** DO FOR YOUR COMPANY?



DIE CASTING

Our depth of experience in die casting allows us to excel at projects that require tight tolerances and unique finishes. We offer polishing, straight lining, painting, and plating.



METAL STAMPING

SCS provides precision metal stamping services. We provide metal stamping product design assistance and rapid turnaround on production tooling and prototyped parts.



PLASTIC INJECTION MOLDING

In our plastic injection molding department we have a wide range of press sizes that can accommodate a variety of parts. We offer in-mold decorating, and applied decorative finishes.



DESIGN AND TOOL BUILDING

Whether it's adapting an existing tool or designing a new tool from concept, we have the expertise to exceed our customer's expectations. Using three-dimensional modeling for tooling, we can accommodate complete detailed mold designs in-house from simple MUD sets to complex dedicated molds.

SCS Elevator Products Inc. is associated and certified with:



BRAILLE
 SIGNAGE
 BUTTONS
 BARRICADES



- INSERT MOLDING
- PAD PRINTING
- HOT STAMPING
- SONIC WELDING
- LASER MARKING
- PLASTIC PLATING
- MID-VOLUME MOLDING
- IN MOLD DECORATING

EXPANDED LINE OF ELEVATOR SIGNS NOW AVAILABLE!

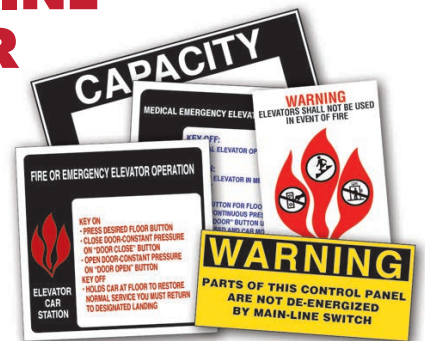

SHOP ONLINE AT
www.scselevatorproducts.com

OR EMAIL US AT
customerservice@scselevatorproducts.com



Mr. Robley G. Cook

A Brief History of SCS Elevator Products Inc.

Robley G. Cook, a visually impaired man, first recognized the need for directional Braille signage to assist those who are also visually impaired. Cook identified the elevator industry as the primary market for his products and approached elevator manufacturers in the USA, soliciting for their business to purchase metal stamped Braille.

In 1983, Mr. Cook became ill and passed away. This presentation of our products and services is dedicated to the memory of our founder, Robley G. Cook, whose respect for quality and devotion to the service of our customers provides daily inspiration for our evolution and achievements. His ideals are still at the heart of what our company is today.



THE LOGO

The SCS logo stands for innovation, precision, and direction. Its distinctive and highly visible form represents two arrows (one up & down) that communicates the company's core mission of helping the visually impaired and society move forward. The colors are chosen to represent innovation and sustainability as well as manufacturing in the USA.



TABLE OF CONTENTS

- 8 CAB BRAILLE CAST**
- 10 CAB BRAILLE CAST/RESIN**
- 11 CAB BRAILLE EMBOSSED METAL**
- 12 JAMB BRAILLE CAST**
- 13 JAMB BRAILLE RESIN/EMBOSSSED**
- 14 PAVE SERIES BUTTONS**
- 16 CONTACT BASES**
- 17 MOUNTING FLANGES & SHIMS**
- 18 DESTINATION DISPATCH**
- 20 SIGNS**
- 22 ADDITIONAL PRODUCTS**
- 24 SAFETY BARRICADES**
- 25 STANDARD COLORS**
- 26 FINISH CODES**
- 27 APPLICATION TECHNIQUE AND CLEANING INSTRUCTIONS**

OUR QUALITY POLICY

SCS is dedicated to providing quality products that meet our customers' requirements, together with on time shipments and at the highest level of service. We are committed to continually improving the effectiveness of our quality management system.

-The Management & Staff of SCS Elevator Products



DIE CAST METAL
CC2 & CC2THIN ANSI COMPLIANT

Part Size 1.248" x 1.248" (± .010")
Thickness 0.085" (0.125" with FLP5) / 0.035"
Corner Radius 0.125"



DIE CAST METAL
CC3 ANSI COMPLIANT

Part Size 1.500" x 1.500" (± .010")
Thickness 0.062"
Corner Radius 0.125"



DIE CAST METAL
CC5 ANSI COMPLIANT

Part Size 1.375" (± .010")
Thickness 0.085"



DIE CAST METAL
CC6 ANSI COMPLIANT

Part Size 1.500" (± .010")
Thickness 0.062"



DIE CAST METAL
CC7

Part Size 0.755" x 1.130" (± .010")
Thickness 0.063"
Corner Radius 0.125"
Character Height 0.629"



DIE CAST METAL
CC10 & CC10THIN ANSI COMPLIANT

Part Size 1.254" x 1.254" (± .010")
Thickness 0.085" (0.125" with FLP5) / 0.035"
Corner Radius 0.175"

STANDARD SPECS (unless otherwise noted)

Finish Satin Nickel, Satin Bronze, Mirrored Stainless or Mirrored Bronze, White, Black, Nickel, Goldleaf or US26
Background Plated Painted
Character Height 0.625"
Standard Font Helvetica Medium
Mounting Standard with Studs, Adhesive Available Upon Request or Back Flange Mounting



DIE CAST METAL
CC16 ANSI COMPLIANT

Part Size 1.417" x 1.248" (± .010")
Thickness 0.085"
Corner Radius 0.125"

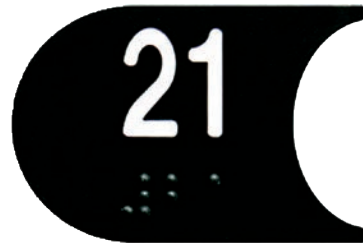

DIE CAST METAL
CK1 ANSI COMPLIANT

Part Size 2.051" x 1.375" (± .010")
Thickness 0.0625"



DIE CAST METAL
CC14 ANSI COMPLIANT

Part Size 1.445" x 1.252" (± .010")
Thickness 0.063"



DIE CAST METAL
CC15 ANSI COMPLIANT

Part Size 1.250" (± .020")
Thickness 0.050"



DIE CAST METAL
LCC5H

Part Size 1.375" (± .010")
Thickness 0.085"
Character Height 0.125"
Mounting (2) Cast Studs

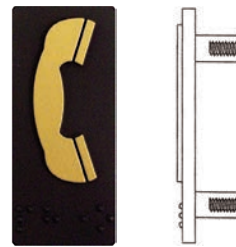

DIE CAST METAL
CCPH1

Part Size 1.000" x 2.250" (± .020")
Thickness 0.125"
Corner Radius 0.063"
Character Height 1.500"
Background Color Painted

STANDARD SPECS (unless otherwise noted)

Designation Color Satin Nickel, Satin Bronze, Mirrored Stainless or Mirrored Bronze. Painted: White, Black, Nickel, Goldleaf or US26.
Background Color Painted
Character Height 0.625"
Standard Font Helvetica Medium
Mounting Standard with Studs, Adhesive Available Upon Request or Back Flange Mounting



DIE CAST METAL
CW1 (FITS DIE CAST CW2 BRAILLE)

Part Size 2.750" x 1.500" (± .010")
Thickness 0.125"
Diameter Opening 1.528"
Mounting Surface or Flush (with flanges)
Finishes Satin Nickel, Satin Bronze, Mirrored Stainless or Mirrored Bronze. Painted: Black, Nickel or Goldleaf.



RESIN
2010056 FITS WITH CCU1 AND RCU1

Part Size 3.480" x 1.700"
Thickness 0.130"
Diameter Opening 1.366" (designed to fit 1.350" button body)
Mounting Studless (uses studs from braille & threaded body of bottom)
Finishes Satin Tri-Chrome - 2010056
 Black - 2010057
 Mirrored Chrome - 2010091
 PVD Mirrored Bronze - 2010141



DIE CAST METAL
CW11190 (FITS DIE CAST CW2 BRAILLE)

Part Size 2.906" x 1.66"
Thickness 0.115"
Diameter Opening 1.190"
Mounting Studless (uses studs from braille & threaded body of button)



DIE CAST METAL
CCU1 ANSI COMPLIANT

Part Size 1.955" x 1.358" (± .010")
Thickness 0.070"



DIE CAST METAL
CW2 ANSI COMPLIANT

Part Size 1.560" x 1.358" (± .010")
Thickness 0.053"



RESIN
RCU1 ANSI COMPLIANT

Part Size 1.955" x 1.358" (± .010")
Thickness 0.070"
Designation Color White
Background Color Black

STANDARD SPECS (unless otherwise noted)

Designation Color Satin Nickel, Satin Bronze, Mirrored Stainless or Mirrored Bronze. Painted: White, Black, Nickel, Goldleaf or US26.
Background Color Painted
Character Height 0.625"
Standard Font Helvetica Medium
Mounting Standard with Studs, Adhesive Available Upon Request or Back Flange Mounting



MARK MUNSON

I really enjoy meeting new people and learning about their company. Working with new and existing customers on projects and helping to make their job easier is what I love.

VICE PRESIDENT OF SALES



EMBOSSSED METAL
EC1 ANSI COMPLIANT

Part Size 1.250" x 1.250" (± .020")
Thickness 0.032"
Corner Radius 0.062"



EMBOSSSED METAL
EK1

Part Size 2.051" x 1.375" (± .020")
Thickness 0.032"



EMBOSSSED METAL
EC1 125 ANSI COMPLIANT

Part Size 1.250" x 1.250" (± .020")
Thickness 0.032"
Corner Radius 0.125"



EMBOSSSED METAL
EC1R

Part Size 1.375" (± .020")
Thickness 0.032"

STANDARD SPECS (unless otherwise noted)

Designation Color	Satin Stainless, Satin Bronze, Mirrored Stainless, Mirrored Bronze, Black or White
Background Color	Natural or Painted
Character Height	0.625"
Standard Font	Helvetica Medium
Mounting	Standard with Adhesive or (1) Stud



JENNIFER MATZEK

Teaming up with our customers to assure they receive the parts they require and have the best customer service experience possible.

SALES TEAM MEMBER/DATA ENTRY



DIE CAST METAL CJT24 ANSI COMPLIANT

Part Size	2.5" x 3.5" (± .010")
Thickness	0.090"
Character Height	2.000"
Corner Radius	0.125"

DIE CAST METAL CJ3

Part Size	3.00" x 4.00" (± .010")
Thickness	0.090"
Corner Radius	0.031"



DIE CAST METAL LCJ229

Part Size	2.500" x 4.000" (± .010")
Thickness	0.080"
Character Height	0.400" Title / 3.000" Designation
Corner Radius	0.125"

RESIN RJ4

Part Size	4.000" x 4.000" (± .010")
Thickness	0.080"
Corner Radius	0.0625"
Designation Color	White
Background Color	Black
Mounting	Adhesive

STANDARD SPECS (unless otherwise noted)

Designation Color	Satin Nickel, Satin Bronze, Mirrored Stainless or Mirrored Bronze. Painted: White, Black, Nickel or Goldleaf.
Background Color	Painted
Standard Font	Helvetica Medium
Mounting	Standard with Studs, Adhesive Available Upon Request or Back Flange Mounting



EMBOSSSED METAL

EJ3 ANSI COMPLIANT

Part Size 3.000" x 3.500" (± .020")
Thickness 0.034"



EMBOSSSED METAL

EJ34

Part Size 3.000" x 4.000" (± .020")
Thickness 0.034"



EMBOSSSED METAL

EJ325 & EJ4 ANSI COMPLIANT

Part Size EJ325 - 3.250" x 3.250" (± .020")
 EJ4 - 4.000" x 4.000"
Thickness 0.034"



EMBOSSSED METAL

EJ45

Part Size 5.000" x 4.000" (± .020")
Thickness 0.034"

EMBOSSSED METAL

EJ5

Part Size 2.750" x 3.750" (± .020")
Thickness 0.034"

DIE CAST METAL

CJ5 CAST FRAME FITS WITH EJ5

Part Size 3.000" x 4.000" (± .010")
Thickness 0.125"
Corner Radius 0.14"
Background Color Satin Nickel, Satin Bronze, Mirrored Stainless or Mirrored Bronze. Painted: White, Black, Nickel or Goldleaf.
Mounting Adhesive or (2) Cast Studs



STANDARD SPECS (unless otherwise noted)

Designation Color Satin Stainless, Satin Bronze, Mirrored Stainless or Mirrored Bronze. Painted: White, Black, Nickel or Goldleaf.
Background Color Natural or Painted
Corner Radius 0.0625"
Character Height 2.000"
Standard Font Helvetica Medium
Mounting Standard with Adhesive, (4) 0.125" Corner Holes with Screws or (2) or (4) 6/32 x .375" Weld Studs

The **PAVE** Series

Protection Against Vandalizing Elevators

Discover our newly redesigned vandal prevention buttons. With 2 body styles and sizes, 3 finish options and 12 target styles available to choose from, our latest PAVE Button is the most versatile that we have ever offered.

Design your own button using numerous combinations available



FINISH CODE	FINISH CODE DESCRIPTION
SS	Stainless Steel
SB	Satin Bronze (PVD Coated)
BK	Black (PVD Coated)

PAVE Series Target Style

			Projecting			
Illuminating			Indicator			
	Flat	Concave	Flat	Concave	Concave	
	PFIL	PCOO	PFOO	PFIO	PCIO	PCIR
CA COMPLIANT						
SS						
SB						

Protect your Elevator









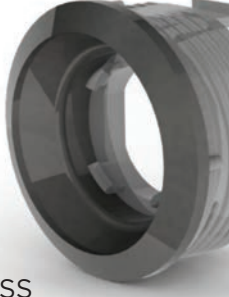
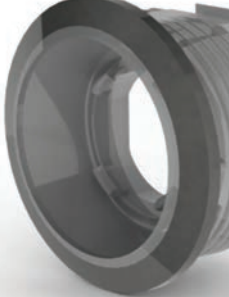
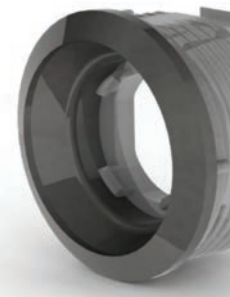
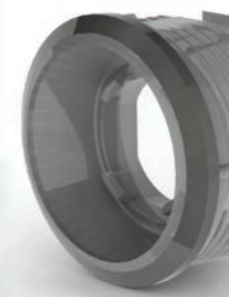
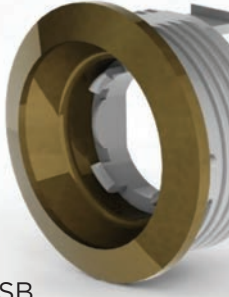
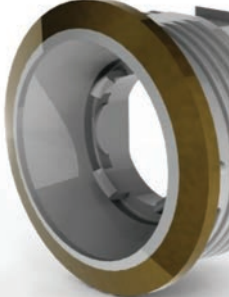
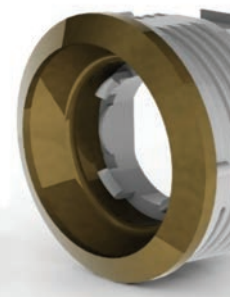
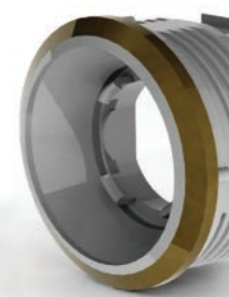



ORDER THE LATEST IN VANDAL PREVENTION



OVER
200
POSSIBLE
COMBINATIONS
PER BODY SIZE

PAVE Series Button Body Styles and Sizes

1.35" No Halo P350	1.35" Halo P35H	1.26" No Halo P260	1.26" Halo P26H
 SS			
 SB			

Rings		Flush				Rings	
		Indicator					
Flat PFIR	Flat PFR0	Domed FD00	Domed FDIO	Domed FDIR	Domed FDRO		
							
							

(800) 783-4633

THE PAVE SERIES BUTTONS

WWW.SCELEVATORPRODUCTS.COM

CONTACT BASES

MULTI-VOLT (3LED) 24 to 120 VOLT



CB3



~~2010018~~ - CB3B
Blue LED



~~2010014~~ - CB3R
Red LED



~~2010020~~ - CB3G
Green LED



~~2010012~~ - CB3W
White LED

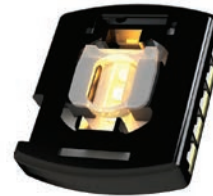

~~2010016~~ - CB3A
Amber LED

CONTACT BASES

MULTI-VOLT (1LED) 6 to 120 VOLT



CB1



~~2009262~~ - CB1B
Blue LED



~~2009260~~ - CB1R
Red LED



~~2009263~~ - CB1G
Green LED



~~2009259~~ - CB1W
White LED

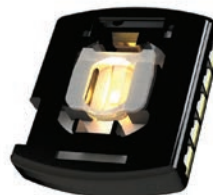

~~2009261~~ - CB1A
Amber LED



~~2009258~~ - CB0
No LED

CONTACT BASES

LOW-VOLT (1LED) 2 VOLT



CB1-LV



~~2012026~~ - CB1R-LV
Red LED

NOTE: Old part numbers have been crossed out with a RED line.

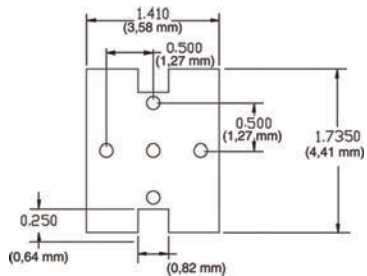

FOR USE WITH: CC2, CC3 ,CC5 ,CC6

FLM1

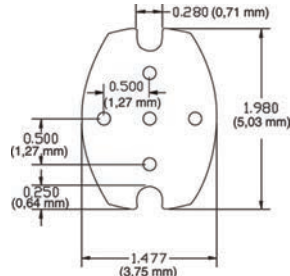

FOR USE WITH: CC2, CC3 ,CC5 ,CC6

FLM2

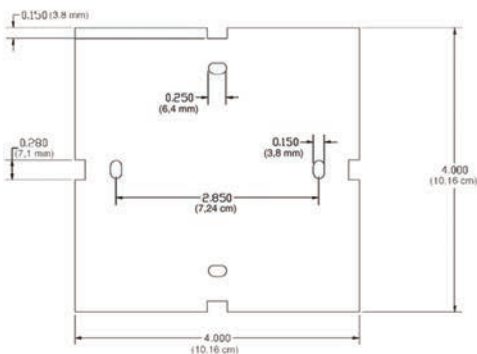

FOR USE WITH: CST1, CJ6

FLM4

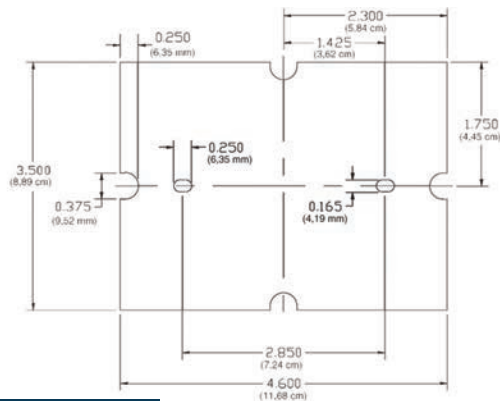

FOR USE WITH: CJT24

FLM5

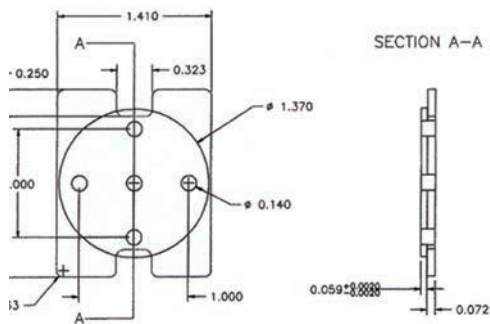

FOR USE WITH: CC5

FLP1

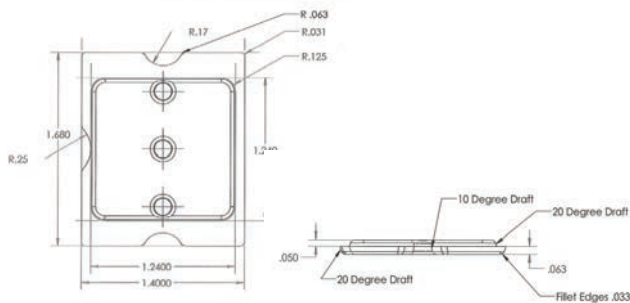

FOR USE WITH: CC2

FLP5



SUE HUFFMAN

I enjoy the personal relationships I develop with our customers when helping them decide the parts they need for their projects. Knowing they are very satisfied and grateful for my help makes my day!

SALES TEAM MEMBER/CUSTOMER CARE

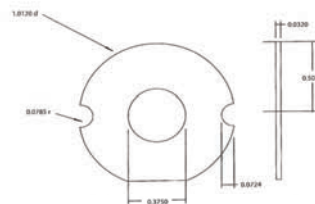

FOR USE WITH: CC2, CC3, CC5, CC6, CC7

SH1R SHIM



DIANA HANSEN

Feeling accomplished when expediting orders to meet a customer's dock date and/or helping customers determine the parts needed.

RFQ COORDINATOR/CUSTOMER CARE



DIE CAST METAL CJ61116B114 CA STAR

Part Size	3.525" x 3.525" (± .010")
Thickness	0.090"
Corner Radius	0.031"
Mounting	Standard with Studs, Adhesive Available Upon Request or Back Flange Mounting

DIE CAST METAL CJ6

Part Size	3.525" x 3.525" (± .010")
Thickness	0.090"
Corner Radius	0.031"
Mounting	Standard with Studs, Adhesive Available Upon Request or Back Flange Mounting

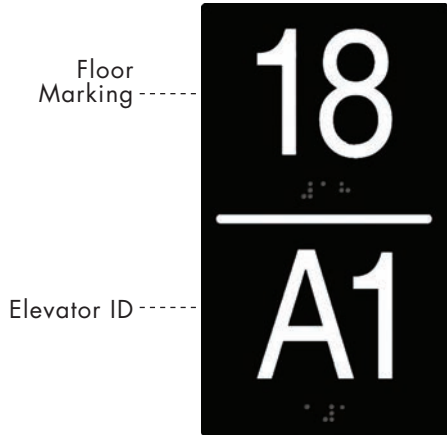

*Many options available!
Please call to request a drawing.*

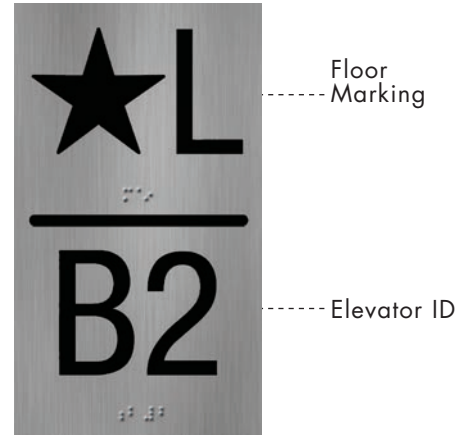

EMBOSSED METAL EJ229 ANSI COMPLIANT

Part Size	4.000" x 7.000" (± .010")
Thickness	0.034"
Corner Radius	0.0625"
Designation Color	White, Satin Stainless, Satin Bronze
Background Color	Black, Satin Stainless, Satin Bronze
Mounting	Standard with Adhesive, (4) 0.125" Corner Holes or (2) Vertical Studs

STAINLESS STEEL DD229 ANSI COMPLIANT

Part Size	4.000" x 7.000" (± .010")
Thickness	18 ga.
Corner Radius	Square
Character Material	Applied Raised Acrylic
Designation Color	Black
Background Color	Satin Stainless
Mounting	Standard with Adhesive or (4) Corner Studs

STANDARD SPECS (unless otherwise noted)

Designation Color	Satin Nickel, Satin Bronze, Mirrored Stainless or Mirrored Bronze. Painted: White, Black, Nickel or Goldleaf.
Character Height	2.000"
Standard Font	Helvetica Medium

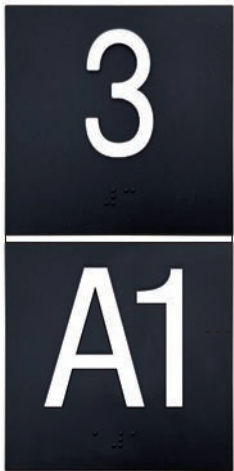

Floor Marking

Elevator ID

DIE CAST METAL

CJ7 ANSI COMPLIANT

Part Size 3.525" x 3.597" (± .010")
Thickness 0.090"



Mounted together, the CJ7 & CJ8 give the appearance of one large die cast plate. Stud locations are available upon request.

DIE CAST METAL

CJ8 ANSI COMPLIANT

Part Size 3.525" x 3.597" (± .010")
Thickness 0.090"

EXPANDED LINE OF ELEVATOR SIGNS NOW AVAILABLE!

SHOP ONLINE AT www.scselevatorproducts.com

OR EMAIL US AT customerservice@scselevatorproducts.com

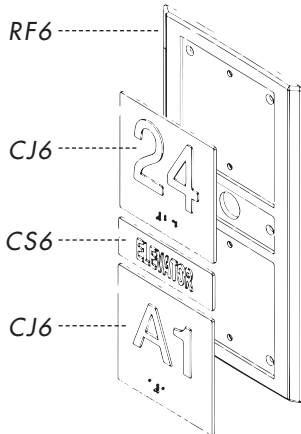

DIE CAST / RESIN

CR229A ANSI COMPLIANT

Part Size 5.190" x 9.780" (± .010")
Thickness 0.230"
Background Color Black Resin Frame with 2 - CJ6 and 1 - CS6
Mounting Adhesive

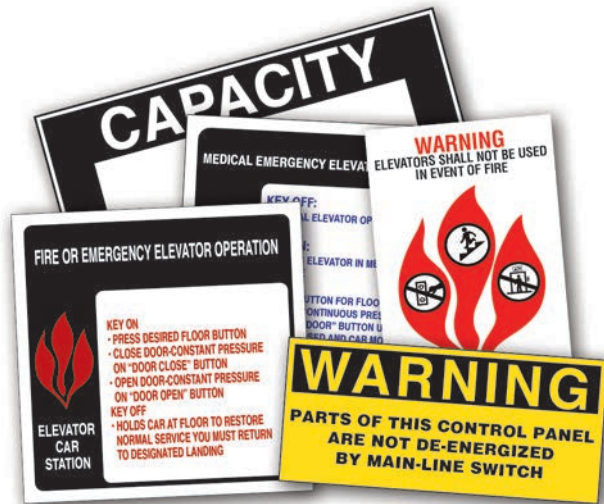

STANDARD SPECS (unless otherwise noted)

Designation Color	Satin Nickel, Satin Bronze, Mirrored Stainless or Mirrored Bronze. Painted: White, Black, Nickel or Goldleaf.
Background Color	Painted
Corner Radius	Square
Character Height	2.000"
Standard Font	Helvetica Medium
Mounting	Standard with Studs, Adhesive Available Upon Request or Back Flange Mounting



METAL / LEXAN

SVB80

Part Size 4.000" x 4.000" (± .010")
Symbol Height 3.130"
Symbol Color Blue
Background Color White Matte Plastic, Satin Stainless, Satin Bronze, Mirrored Stainless or Mirrored Bronze

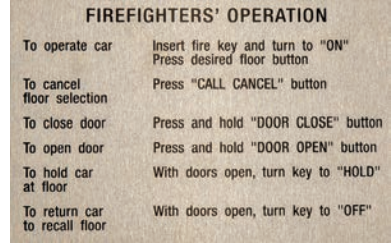

METAL / LEXAN

SVB12 PHASE II ANSI 1993

Part Size 6.900" x 4.400" (± .010")
Character Height 0.250" Title / 0.188" Text
Text Color Black or White
Background Color White or Black Matte Plastic, Satin Stainless, Satin Bronze, Mirrored Stainless or Mirrored Bronze

Also Available:
 SVB41 - PHASE II ANSI 1996
 SVB59 - PHASE II ANSI 1998
 SVB79 - PHASE II ANSI 2000



SVB70R - Not available in Black Matte Plastic

METAL / LEXAN

SVB6 PHASE I ANSI COMPLIANT

Part Size 4.000" x 1.450" (± .010")
Character Height 0.250"
Text Color Black
Background Color White Matte Plastic, Satin Stainless, Satin Bronze, Mirrored Stainless or Mirrored Bronze

METAL / LEXAN

SVB70 & SVB70R PHASE I ANSI COMPLIANT

Part Size 3.375" x 3.000" (± .015)
Character Height 0.250" Title / 0.188" Text
Text Color White or Black
Background Color Black Matte Plastic, Satin Stainless, Satin Bronze, Mirrored Stainless or Mirrored Bronze



Also available in:

Codes
 FL: SVB104
 MD: SVB31
 HOUSTON: SVB123



2011060 ICOF Braille Plate 5.000" x 2.000" (± .020")



METAL / LEXAN

SVB13 ANSI COMPLIANT APPENDIX H, APPENDIX O

Part Size 5.000" x 8.000" (± .020")
Character Height 0.300" Text / 6.000" Flame Graphic
Flame/Picto Color Black Text and Pictograms, Red Flame
Background Color White Matte Plastic, Satin Stainless, Satin Bronze, Mirrored Stainless or Mirrored Bronze

METAL / LEXAN

SVB30 CA CODE

Part Size 5.000" x 8.000" (± .020")
Character Height 0.300" Text / 4.000" Flame Graphic
Flame/Picto Color Black Text and Pictograms, Red Flame
Background Color White Matte Plastic, Satin Stainless, Satin Bronze, Mirrored Stainless or Mirrored Bronze

STANDARD SPECS (unless otherwise noted)

Material Thickness 0.032" - Metal / 0.020" - Lexan
Corner Radius Square
Standard Font Helvetica Medium
Mounting Adhesive

*Metal plate is for display view only

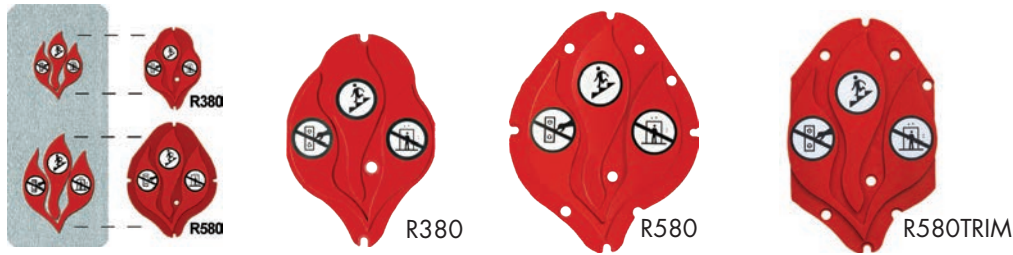

RESIN (INSERT ONLY)
R380, R580 & R580TRIM

Part Size R380 - 3.130" x 4.110"
 R580 - 4.221" x 5.938"
 R580TRIM - 4.310" x 6.830"

Flame/Picto Color Red Flame, Black Pictograms with White, Satin Stainless or Satin Bronze Background

Mounting Back Flange Flush Mount

Cutout 2D Part Outline File Provided upon request, When requesting indicate preferred file format.



ALUMINUM
SUBCAP CAPACITY PLATE

Part Size 3.250" x 1.250" (± .020")
Character Height 0.375"
Thickness 0.020" Aluminum



ALUMINUM
SUB229COP PHASE I ANSI COMPLIANT

Part Size 3.250" x 1.250" (± .020")
Character Height 0.500"
Thickness 0.020" Aluminum

CAST / RESIN
CST1 / RST1 ANSI COMPLIANT

Part Size CST1 (Cast) - 3.490" x 3.490" (± .010")
 RST1 (Resin) - 3.510" x 3.510" (± .010")

Corner Radius 0.125"

Part Thickness 0.125"

Symbol Color Blue

Background Color CST1 - Satin Stainless, Satin Bronze, Mirrored Stainless, Mirrored Bronze.
 Painted: White, Nickel or Goldleaf

RST1 - White or Satin Silver

Mounting CST1 - Standard with Studs, Adhesive Available Upon Request or Back Flange Mounting
 RST1 - Adhesive Only



ALUMINUM
SUB229 ANSI COMPLIANT APPENDIX H, APPENDIX O

Part Size 4.000" x 4.000" (± .010")
Character Height 0.625" Title / 3.000" Designation
Thickness 0.020" Aluminum

STANDARD SPECS (unless otherwise noted)

Thickness 0.020"

Text Color White, Black, Satin Silver or Satin Gold

Background Color Black, Satin Silver or Satin Gold

Standard Font Helvetica Medium

Mounting Adhesive



DIE CAST METAL
CC22.425 ANSI COMPLIANT

Part Size	2.425" x 1.250" (± .010")
Thickness	0.085"
Corner Radius	0.125"
Character Height	0.625"
Designation Color	*See Cast Finishes below
Background Color	Painted
Mounting	Standard with Studs or Adhesive Available Upon Request



DIE CAST METAL
CPI ANSI COMPLIANT

Part Size	1.575" x 1.063" (± .010")
Thickness	0.052"
Corner Radius	0.059"
Symbol Height	0.500"
Symbol Color	*See Cast Finishes below
Background Color	Painted
Mounting	Adhesive Only



DIE CAST METAL
CM1

Part Size	2.495" (± .010") diameter opening
Overall Part Thickness	0.187"
Symbol Color	Painted Red and Black
Background Finish	*See Cast Finishes below
Mounting	2.990" sq. Back Flange Flush Mount, 4 x 0.200" Mounting Holes



DIE CAST METAL
CPI

Part Size	3.375" x 1.125" (± .010")
Thickness	0.125"
Capacity Height	0.250" Raised
Duty Load Height/Color	0.240" / Black Laser Etched
Background Color	*See Cast Finishes below
Mounting	Standard with Studs or Adhesive Available Upon Request

Over 400 layouts offered! Please call to request drawing.

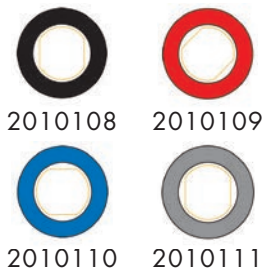

RESIN
KEY SWITCH COLLARS

Part Size	1.340" round
	Please request drawing
Flats	.635 or .692
Text Color	White
Mounting	Surface Mount

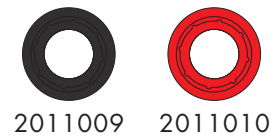

RESIN
KEY SWITCH COLLAR HALO

Part Size	1.700" round O.D.
	Please request drawing
Mating Parts	2010108, 2010109, 2010110, 2010111

STANDARD SPECS (unless otherwise noted)

Cast Finishes	Satin Nickel, Satin Bronze, Mirrored Stainless or Mirrored Bronze. Painted: White, Black, Nickel or Goldleaf.
Standard Font	Helvetica Medium



BRIAN HILFRANK

Identifying a customer's pain, then collaboratively figuring out a way to match the companies capabilities in order to eliminate that pain, is what I find the most gratifying.

REGIONAL SALES MANAGER



Please Call SCS for Braille Tags

DIE CAST METAL

CFHR

- Part Size** 3.078" round ($\pm .010$ ")
- Part Thickness** 0.125"
- Symbol Color** Satin Nickel, Satin Bronze, Mirrored Stainless or Mirrored Bronze. Painted: White, Black, Nickel or Goldleaf.
- Background Color** Painted
- Mounting** Standard with Studs, Adhesive Available Upon Request

DIE CAST METAL

CI58HE

- Character Height** 0.625"
- Finish** Satin Stainless, Satin Bronze, Mirrored Stainless or Mirrored Bronze. Painted: White, Black Nickel or Goldleaf.
- Mounting** Standard with Studs



METAL

SVB136RSS

- Part Size** 3.500" x 3.500"
- Fireman's Hat Color** Red - Silk Screened
- Background Color** Satin Stainless, Satin Bronze, Mirrored Stainless or Mirrored Bronze



DIE CAST METAL

CSOL

- Part Size** 3.091" ($\pm .010$ ")
- Thickness** 0.125"
- Symbol Color** Blue with White Snake
- Mounting** Standard with Studs, Adhesive Available Upon Request



RESIN BOARD

EARED BARRICADE - 2017115

Approx. Spread Size 100" x 36" (Combine sets for a wider barricade)
 Panels Per Set 4



RESIN BOARD

HINGED BARRICADE - 2017215

Approx. Spread Size 110" x 36"
 Panels Per Set 4 - Comes Assembled



CORRUGATED PLASTIC

SINGLE PANELS, EARED BARRICADE

Thickness 0.394"
 Panel Size 29.5" x 42"
 Text/Picto Color Black



Available April 2019

STANDARD SPECS (unless otherwise noted)

Thickness 0.236"
 Text/Picto Color Black and Red
 Background Color Safety Yellow

- Customized graphics also available
- Free standing and portable

- Easy to assemble and dismantle for use and storage
- Strong and resilient for interior or exterior use



NICKEL - GC-56887-A

NICPAINT56887GC



GOLDLEAF - FINE RICH GOLD

GOLD113



BLUE - BLUE (7)

F63TXL132034347

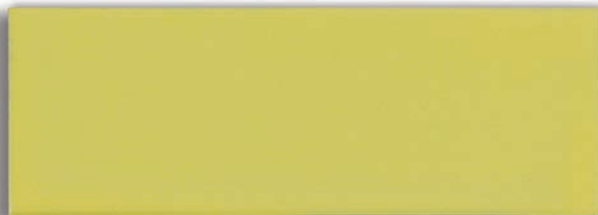

YELLOW - YELLOW (11)

F73XXY196934347

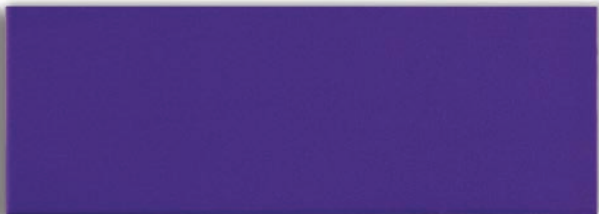

PURPLE - MEDIUM PURPLE C

F63TXP30819-4347



GREEN - PANTONE 355C

F63TXG19163-4347



BLACK - FLAT BLACK (2)

F63TXB38994347

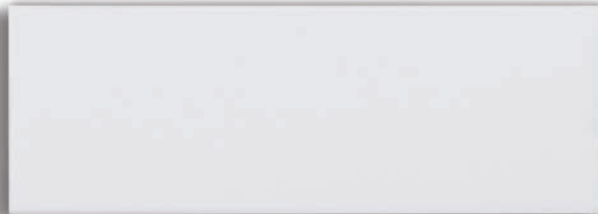

WHITE - STAMP WHITE (9)

F63BXW96124347



RED - RED (8)

F63TXR38384347



ORANGE - PANTONE 1655C

F63TXE30806-4347

STANDARD COLORS DISCLAIMER

We strive to make the colors shown as accurate as possible. However, the colors printed above may not be an accurate depiction of the actual color. These images should be used as a guide only. If you would like a sample of any item, please contact us at 800-783-4633 or email us at info@scselevatorproducts.com.

METAL EMBOSSED / SIGNS

OPTION CODES	CHARACTER FINISH	BACKGROUND FINISH
BSS	Black	Satin Stainless
SSB	Satin Stainless	Black
BMS	Black	Mirrored Stainless
MSB	Mirrored Stainless	Black
BSB	Black	Satin Bronze
SBB	Satin Bronze	Black
BMB	Black	Mirrored Bronze
MBB	Mirrored Bronze	Black
WB	White	Black

DIE CAST

OPTION CODES	CHARACTER FINISH	BACKGROUND FINISH
SNB	Satin Nickel	Black
SBB	Satin Bronze	Black
WB	White	Black
US26B	US26	Black
MSB	Mirrored Stainless	Black
MBB	Mirrored Bronze	Black
NICB	Nickle Painted	Black
BNIC	Black	Nickle Painted
GLB	Goldleaf Painted	Black
BGL	Black	Goldleaf Painted



JAMIE KELLS

I love building relationships with my customers, taking time to fully understand what my customers are looking for and finding a solution to help them. SCS Elevator Products has so many unique products to offer, let me show you how we can be your solution.

SALES AND MARKETING

APPLICATION TECHNIQUE FOR ADHESIVE MOUNTED PARTS

To obtain optimum adhesion, the bonding surfaces must be clean and dry. We recommend you use a cleaning solvent mixture of isopropyl alcohol (rubbing alcohol) and water mixture (50/50 mix). Use proper safety precautions for handling solvent.

It may be necessary to seal or prime some surfaces prior to bonding. For instance, most porous fibred material (e.g wood) will require sealing to provide a unified surface. Firm pressure around perimeter of plate, when applying, develops better adhesive contact and thus improves bond strength.

The ideal application temperature range is 70° to 100° F (21° to 38° C). Application to surface at temperatures below 50° F (10° C) is not recommended because the adhesive becomes too firm to adhere readily. In some cases bond strength can be increased and ultimate bond strength can be achieved more quickly by exposure of the bond to elevated temperatures (e.g 150° F (66° C) for 1 hour). This provides better adhesive onto the surfaces.

Plates may appear to have slight bend. With proper application using the above directions, adhesive should overcome any such bend. If you have any questions regarding these instructions, please contact our office anytime.

CLEANING INSTRUCTIONS

Cleaning can be accomplished by wiping with a damp cloth and wiping dry. Make sure that a very soft cloth such a flannel or equivalent is used and that all wiping is done in the direction of the grain. Make sure that only light pressure is applied when wiping the material. Abrasive cleaners or materials should never be used.

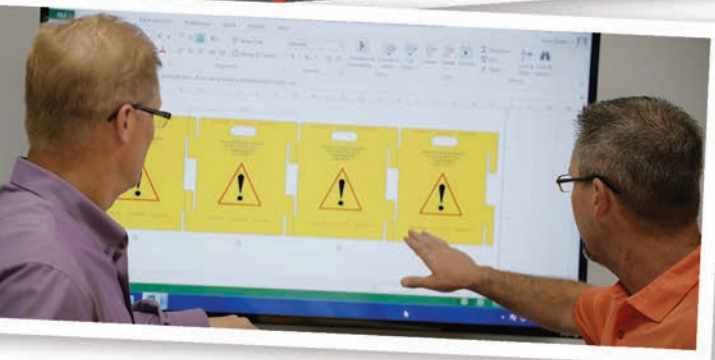



ELEVATOR PRODUCTS INC.

310 Cannon River Avenue North
Red Wing, Minnesota 55066

info@scselevatorproducts.com

A WORLDWIDE SUPPLIER OF QUALITY COMPONENTS FOR THE ELEVATOR INDUSTRY

(800) 783-4633

www.SCSElevatorProducts.com